

SITUATED IN AND BEING PART OF
The State of Ohio, County of Muskingum, and being
part of the Township of Falls, Third Quarter, T1N, R7W,
U.S.M.L., and being part of the City of Zanesville, Ward 5.

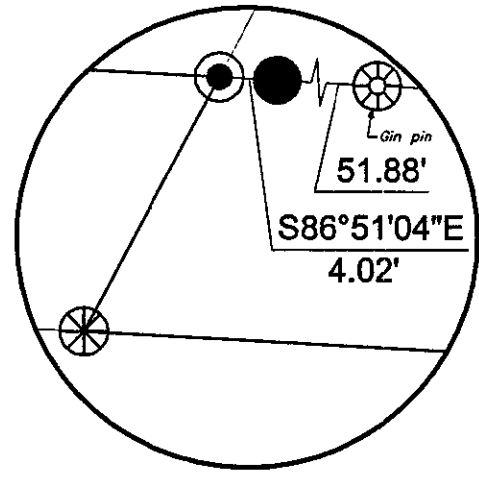
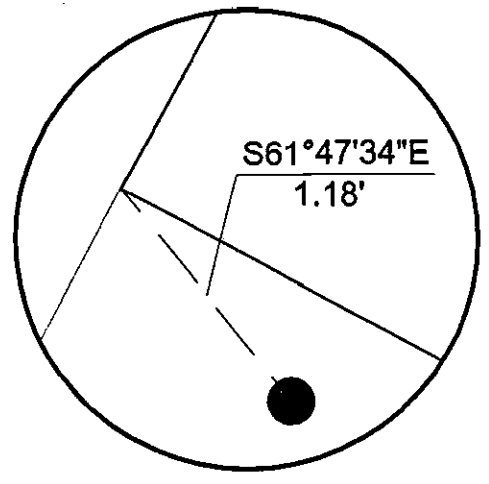

Note: Original deeds call for property
to extend to river, but railroad right
of way maps show right of way to
waters edge of river.

Armco Steel Corporation
Tract Two
±8.270 Acres
DR 194-596
DR 216-536
DR 832-334

Armco Steel Corporation
Tract Three
±0.220 Acres
DR 216-536

Armco Steel Corporation
Tract One
±41.893 Acres
DR 174-309
DR 404-474
DR 577-865
DR 577-871
DR 608-303
DR 832-334

OFFICE COPY
NOT RECORDABLE

- LEGEND
- Iron Pin Set, 5/8" rebar
- Iron Pin Found
- Axle Found
- Pipe Found
- ⊠ Monument Found
- Bolt Found
- ⊙ Copper Plug in Sidewalk
- ⊗ Chiseled Cross in Concrete
- ⊙ PK Nail
- Property Hook
- (17-68) Tax Map e.g.
- (03) Block No. e.g.
- 44 Parcel No. e.g.

BASIS OF BEARING
Bearings are based on Ohio State Plane Coordinate
System, NAD 83, South Zone Grid North, as per
GPS Observations.

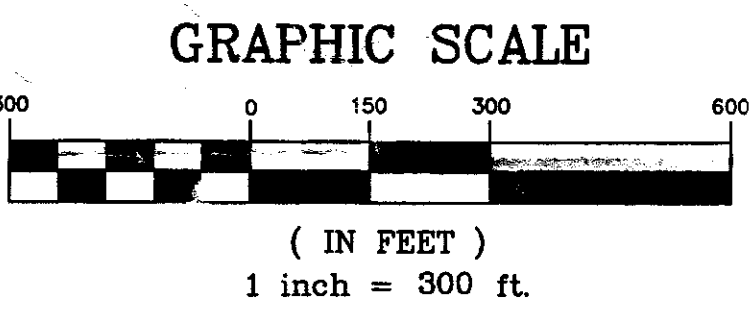

- TRACT ONE
- PARCEL NO.
- All of: 80-85-12-01-01-000 = (±0.106 ac.)
- All of: 80-85-12-01-02-000 = (±0.474 ac.)
- All of: 80-85-12-01-03-000 = (±0.119 ac.)
- All of: 80-85-12-01-04-000 = (±0.119 ac.)
- All of: 80-85-12-01-05-000 = (±0.119 ac.)
- All of: 80-85-12-01-06-000 = (±0.119 ac.)
- All of: 80-85-12-01-07-000 = (±0.119 ac.)
- All of: 80-85-12-01-08-000 = (±0.119 ac.)
- All of: 80-85-12-01-09-000 = (±0.119 ac.)
- All of: 80-85-12-01-10-000 = (±0.119 ac.)
- All of: 80-85-12-01-11-000 = (±0.190 ac.)
- All of: 80-85-12-01-12-000 = (±0.350 ac.)
- All of: 80-85-12-01-13-000 = (±0.106 ac.)
- All of: 80-85-12-01-14-000 = (±0.106 ac.)
- All of: 80-85-12-01-15-000 = (±0.106 ac.)
- All of: 80-85-12-01-16-000 = (±0.106 ac.)
- All of: 80-85-13-01-01-000 = (±0.950 ac.)
- All of: 80-85-13-01-02-000 = (±4.870 ac.)
- All of: 80-85-15-01-01-700 = (±28.458 ac.)
- All of: 80-85-15-01-02-000 = (±0.485 ac.)
- All of: 80-85-15-01-03-000 = (±0.485 ac.)
- All of: 80-85-15-01-04-000 = (±0.485 ac.)
- All of: 80-85-15-01-05-000 = (±0.485 ac.)
- All of: 80-85-15-01-06-000 = (±0.242 ac.)
- All of: 80-85-15-01-07-000 = (±0.242 ac.)
- All of: 80-85-15-01-08-000 = (±0.119 ac.)
- All of: 80-85-15-01-09-000 = (±0.119 ac.)
- All of: 80-85-15-01-10-000 = (±0.119 ac.)
- All of: 80-85-15-01-11-000 = (±0.119 ac.)
- All of: 80-85-15-01-12-000 = (±0.119 ac.)
- All of: 80-85-15-01-13-000 = (±0.119 ac.)
- All of: 80-85-15-01-14-000 = (±0.119 ac.)
- All of: 80-85-15-01-15-000 = (±0.119 ac.)
- All of: 80-85-15-01-16-000 = (±0.119 ac.)
- All of: 80-85-15-01-17-000 = (±0.119 ac.)
- All of: 80-85-15-01-18-000 = (±0.119 ac.)
- All of: 80-85-15-01-19-000 = (±0.119 ac.)
- All of: 80-85-15-01-20-000 = (±0.119 ac.)
- All of: 80-85-15-01-21-000 = (±0.119 ac.)
- All of: 80-85-15-01-22-000 = (±0.119 ac.)
- All of: 80-85-15-01-23-000 = (±0.119 ac.)
- All of: 80-85-15-01-24-000 = (±0.119 ac.)
- All of: 80-85-15-01-25-000 = (±0.119 ac.)
- All of: 80-85-15-01-26-000 = (±0.119 ac.)
- All of: 80-85-15-01-27-000 = (±0.119 ac.)
- All of: 80-85-15-01-28-000 = (±0.119 ac.)
- All of: 80-85-15-01-29-000 = (±0.119 ac.)
- All of: 80-85-15-01-30-000 = (±0.119 ac.)
- All of: 80-85-15-01-31-000 = (±0.119 ac.)
- All of: 80-85-15-01-32-000 = (±0.119 ac.)
- All of: 80-85-15-01-33-000 = (±0.119 ac.)
- All of: 80-85-15-01-34-000 = (±0.119 ac.)
- All of: 80-85-15-01-35-000 = (±0.119 ac.)
- All of: 80-85-15-01-36-000 = (±0.119 ac.)
- All of: 80-85-15-01-37-000 = (±0.119 ac.)
- All of: 80-85-15-01-38-000 = (±0.119 ac.)
- All of: 80-85-15-01-39-000 = (±0.119 ac.)
- All of: 80-85-15-01-40-000 = (±0.119 ac.)
- All of: 80-85-15-01-41-000 = (±0.119 ac.)
- All of: 80-85-15-01-42-000 = (±0.119 ac.)
- All of: 80-85-15-01-43-000 = (±0.119 ac.)
- All of: 80-85-15-01-44-000 = (±0.119 ac.)
- All of: 80-85-15-01-45-000 = (±0.119 ac.)
- All of: 80-85-15-01-46-000 = (±0.119 ac.)
- All of: 80-85-15-01-47-000 = (±0.119 ac.)
- All of: 80-85-15-01-48-000 = (±0.119 ac.)
- All of: 80-85-15-01-49-000 = (±0.119 ac.)
- All of: 80-85-15-01-50-000 = (±0.119 ac.)
- All of: 80-85-15-01-51-000 = (±0.119 ac.)
- All of: 80-85-15-01-52-000 = (±0.119 ac.)
- All of: 80-85-15-01-53-000 = (±0.119 ac.)
- All of: 80-85-15-01-54-000 = (±0.119 ac.)
- All of: 80-85-15-01-55-000 = (±0.119 ac.)
- All of: 80-85-15-01-56-000 = (±0.119 ac.)
- All of: 80-85-15-01-57-000 = (±0.119 ac.)
- All of: 80-85-15-01-58-000 = (±0.119 ac.)
- All of: 80-85-15-01-59-000 = (±0.119 ac.)
- All of: 80-85-15-01-60-000 = (±0.119 ac.)
- All of: 80-85-15-01-61-000 = (±0.119 ac.)
- All of: 80-85-15-01-62-000 = (±0.119 ac.)
- All of: 80-85-15-01-63-000 = (±0.119 ac.)
- All of: 80-85-15-01-64-000 = (±0.119 ac.)
- All of: 80-85-15-01-65-000 = (±0.119 ac.)
- All of: 80-85-15-01-66-000 = (±0.119 ac.)
- All of: 80-85-15-01-67-000 = (±0.119 ac.)
- All of: 80-85-15-01-68-000 = (±0.119 ac.)
- All of: 80-85-15-01-69-000 = (±0.119 ac.)
- All of: 80-85-15-01-70-000 = (±0.119 ac.)
- All of: 80-85-15-01-71-000 = (±0.119 ac.)
- All of: 80-85-15-01-72-000 = (±0.119 ac.)
- All of: 80-85-15-01-73-000 = (±0.119 ac.)
- All of: 80-85-15-01-74-000 = (±0.119 ac.)
- All of: 80-85-15-01-75-000 = (±0.119 ac.)
- All of: 80-85-15-01-76-000 = (±0.119 ac.)
- All of: 80-85-15-01-77-000 = (±0.119 ac.)
- All of: 80-85-15-01-78-000 = (±0.119 ac.)
- All of: 80-85-15-01-79-000 = (±0.119 ac.)
- All of: 80-85-15-01-80-000 = (±0.119 ac.)
- All of: 80-85-15-01-81-000 = (±0.119 ac.)
- All of: 80-85-15-01-82-000 = (±0.119 ac.)
- All of: 80-85-15-01-83-000 = (±0.119 ac.)
- All of: 80-85-15-01-84-000 = (±0.119 ac.)
- All of: 80-85-15-01-85-000 = (±0.119 ac.)
- All of: 80-85-15-01-86-000 = (±0.119 ac.)
- All of: 80-85-15-01-87-000 = (±0.119 ac.)
- All of: 80-85-15-01-88-000 = (±0.119 ac.)
- All of: 80-85-15-01-89-000 = (±0.119 ac.)
- All of: 80-85-15-01-90-000 = (±0.119 ac.)
- All of: 80-85-15-01-91-000 = (±0.119 ac.)
- All of: 80-85-15-01-92-000 = (±0.119 ac.)
- All of: 80-85-15-01-93-000 = (±0.119 ac.)
- All of: 80-85-15-01-94-000 = (±0.119 ac.)
- All of: 80-85-15-01-95-000 = (±0.119 ac.)
- All of: 80-85-15-01-96-000 = (±0.119 ac.)
- All of: 80-85-15-01-97-000 = (±0.119 ac.)
- All of: 80-85-15-01-98-000 = (±0.119 ac.)
- All of: 80-85-15-01-99-000 = (±0.119 ac.)
- All of: 80-85-15-01-100-000 = (±0.119 ac.)
- TOTAL = (±41.893 ac.)

- TRACT TWO
- PARCEL NO.
- All of: 80-85-15-02-01-000 = (±0.110 ac.)
- All of: 80-85-15-02-02-000 = (±0.110 ac.)
- All of: 80-85-15-02-03-000 = (±0.110 ac.)
- All of: 80-85-15-02-04-000 = (±0.110 ac.)
- All of: 80-85-15-02-05-000 = (±0.110 ac.)
- All of: 80-85-15-02-06-000 = (±0.110 ac.)
- All of: 80-85-15-02-07-000 = (±0.110 ac.)
- All of: 80-85-15-02-08-000 = (±0.110 ac.)
- All of: 80-85-15-02-09-000 = (±0.110 ac.)
- All of: 80-85-15-02-10-000 = (±0.110 ac.)
- All of: 80-85-15-02-11-000 = (±0.110 ac.)
- All of: 80-85-15-02-12-000 = (±0.110 ac.)
- All of: 80-85-15-02-13-000 = (±0.275 ac.)
- All of: 80-85-15-02-14-000 = (±5.189 ac.)
- All of: 80-85-15-02-15-000 = (±0.083 ac.)
- All of: 80-85-15-03-01-000 = (±0.110 ac.)
- All of: 80-85-15-03-02-000 = (±0.110 ac.)
- All of: 80-85-15-03-03-000 = (±0.110 ac.)
- All of: 80-85-15-03-04-000 = (±0.110 ac.)
- All of: 80-85-15-03-05-000 = (±0.110 ac.)
- All of: 80-85-15-03-06-000 = (±0.110 ac.)
- All of: 80-85-15-03-07-000 = (±0.110 ac.)
- All of: 80-85-15-03-08-000 = (±0.110 ac.)
- All of: 80-85-15-03-09-000 = (±0.110 ac.)
- All of: 80-85-15-03-10-000 = (±0.110 ac.)
- All of: 80-85-15-03-11-000 = (±0.110 ac.)
- All of: 80-85-15-03-12-000 = (±0.110 ac.)
- All of: 80-85-15-03-13-000 = (±0.083 ac.)
- TOTAL = (±8.270 ac.)

- TRACT THREE
- PARCEL NO.
- All of: 80-85-15-04-01-000 = (±0.110 ac.)
- All of: 80-85-15-04-02-000 = (±0.110 ac.)
- TOTAL = (±0.220 ac.)

- TRACT FOUR
- PARCEL NO.
- All of: 18-17-65-03-01-000 = (±8.030 ac.)
- All of: 18-17-65-03-02-000 = (±5.210 ac.)
- All of: 18-17-65-03-03-000 = (±5.030 ac.)
- All of: 18-17-65-03-04-000 = (±4.750 ac.)
- All of: 18-17-65-03-05-000 = (±0.133 ac.)
- All of: 18-17-65-03-06-000 = (±0.133 ac.)
- All of: 18-17-65-03-07-000 = (±0.133 ac.)
- All of: 18-17-65-03-08-000 = (±0.133 ac.)
- All of: 18-17-65-03-09-000 = (±0.133 ac.)
- All of: 18-17-65-03-10-000 = (±0.133 ac.)
- All of: 18-17-65-03-11-000 = (±0.133 ac.)
- All of: 18-17-65-03-12-000 = (±0.133 ac.)
- All of: 18-17-65-03-13-000 = (±0.133 ac.)
- All of: 18-17-65-03-14-000 = (±0.133 ac.)
- All of: 18-17-65-03-15-000 = (±0.160 ac.)
- All of: 18-17-65-03-16-000 = (±0.133 ac.)
- All of: 18-17-65-03-17-000 = (±0.133 ac.)
- All of: 18-17-65-03-18-000 = (±0.133 ac.)
- All of: 18-17-65-03-19-000 = (±0.133 ac.)
- All of: 18-17-65-03-20-000 = (±0.133 ac.)
- All of: 18-17-65-03-21-000 = (±0.133 ac.)
- All of: 18-17-65-03-22-000 = (±0.133 ac.)
- All of: 18-17-65-03-23-000 = (±0.133 ac.)
- All of: 18-17-65-03-24-000 = (±0.133 ac.)
- All of: 18-17-65-03-25-000 = (±0.133 ac.)
- All of: 18-17-65-03-26-000 = (±0.140 ac.)
- All of: 18-17-65-03-27-000 = (±0.140 ac.)
- All of: 18-17-65-03-28-000 = (±0.140 ac.)
- All of: 18-17-65-03-29-000 = (±0.140 ac.)
- All of: 18-17-65-03-30-000 = (±0.140 ac.)
- All of: 18-17-65-03-31-000 = (±0.140 ac.)
- All of: 18-17-65-03-32-000 = (±0.140 ac.)
- All of: 18-17-65-03-33-000 = (±0.140 ac.)
- All of: 18-17-65-03-34-000 = (±0.140 ac.)
- All of: 18-17-65-03-35-000 = (±0.140 ac.)
- All of: 18-17-65-03-36-000 = (±0.140 ac.)
- All of: 18-17-65-03-37-000 = (±0.140 ac.)
- All of: 18-17-65-03-38-000 = (±0.140 ac.)
- All of: 18-17-65-03-39-000 = (±0.140 ac.)
- All of: 18-17-65-03-40-000 = (±0.140 ac.)
- All of: 18-17-65-03-41-000 = (±0.140 ac.)
- All of: 18-17-65-03-42-000 = (±0.140 ac.)
- All of: 18-17-65-03-43-000 = (±0.140 ac.)
- All of: 18-17-65-03-44-000 = (±0.140 ac.)
- All of: 18-17-65-03-45-000 = (±0.140 ac.)
- All of: 18-17-65-03-46-000 = (±0.140 ac.)
- All of: 18-17-65-03-47-000 = (±0.140 ac.)
- All of: 18-17-65-03-48-000 = (±0.140 ac.)
- All of: 18-17-65-03-49-000 = (±0.140 ac.)
- All of: 18-17-65-03-50-000 = (±0.140 ac.)
- All of: 18-17-65-03-51-000 = (±0.140 ac.)
- All of: 18-17-65-03-52-000 = (±0.140 ac.)
- All of: 18-17-65-03-53-000 = (±0.140 ac.)
- All of: 18-17-65-03-54-000 = (±0.169 ac.)
- All of: 18-17-65-03-55-000 = (±0.169 ac.)
- All of: 18-17-65-03-56-000 = (±0.140 ac.)
- All of: 18-17-65-03-57-000 = (±0.140 ac.)
- All of: 18-17-65-03-58-000 = (±0.140 ac.)
- All of: 18-17-65-03-59-000 = (±0.140 ac.)
- All of: 18-17-65-03-60-000 = (±0.140 ac.)
- All of: 18-17-65-03-61-000 = (±0.140 ac.)
- All of: 18-17-65-03-62-000 = (±0.140 ac.)
- All of: 18-17-65-03-63-000 = (±0.140 ac.)
- All of: 18-17-65-03-64-000 = (±0.140 ac.)
- All of: 18-17-65-03-65-000 = (±0.140 ac.)
- All of: 18-17-65-03-66-000 = (±0.140 ac.)
- All of: 18-17-65-03-67-000 = (±0.140 ac.)
- All of: 18-17-65-03-68-000 = (±0.140 ac.)
- All of: 18-17-65-03-69-000 = (±4.550 ac.)
- All of: 18-17-65-03-70-000 = (±4.180 ac.)
- All of: 18-17-65-03-71-000 = (±2.990 ac.)
- All of: 18-17-65-03-72-000 = (±0.770 ac.)
- All of: 18-17-65-03-73-000 = (±0.320 ac.)
- TOTAL = (±44.037 ac.)

- REFERENCES
- DR 173-322
- DR 174-309
- DR 194-596
- DR 216-536
- DR 234-110
- DR 234-196
- DR 404-474
- DR 577-865
- DR 577-871
- DR 608-303
- DR 832-334
- Tax Map 17-65
- Tax Map 17-66
- Tax Map 85-12
- Tax Map 85-13
- Tax Map 85-14
- Tax Map 85-15
- Tax Map 85-23
- Plat Book 2, Page 4
- Plat Book 2, Page 32
- Plat Book 2, Page 124
- Plat Book 2, Page 125
- Plat Book 4, Page 130
- R/W Map, Wheeling & Lake Erie R.R. Co. V2/129
- R/W Map, Wheeling & Lake Erie R.R. Co. V2/130
- R/W Map, Wheeling & Lake Erie R.R. Co. V2/130

DESCRIPTION APPROVED
FOR AUDITOR'S TRANSFER
BY [Signature]
L-5-1003

OFFICE COPY
NOT RECORDABLE
Date _____
Reg. Surveyor No. 7321

Sheet No.	Project No.	By	Date	Scale	Revisions	By	Date
1	AK-383	Designed	JDN	Horiz. 1" = 300'			
		Drawn	VHC	Vert. 1" = N/A			
		Checked	THL	Field Book No.			
		Approved	THL				

A K STEEL
LINDEN AVENUE SITE
ZANESVILLE, OHIO
BOUNDARY SURVEY

Linn Engineering, Inc.
Civil Engineering Consultants
P.O. Box 2086 Zanesville, Ohio 43702-2086 740-452-7434